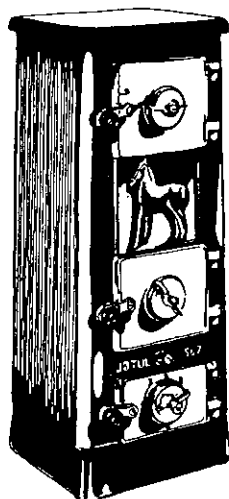

TABLE OF CONTENTS

JOTUL NO. 507



1. Illustration Index
2. Repair Times
3. Stove Description
4. Design Changes
5. Trouble Shooters Guide
6. Directions for Part Replacement
 - A. Top Plate
 - B. Top Plate Asbestos Gasket
 - C. Back Plate
 - D. Front Plate
 - E. Side Plate
 - F. Bottom Plate
 - G. Door Gaskets
 - H. Door Handle Catch
 - I. Door Pins
 - J. Firebricks
 - K. Shaker Grate

JOTUL NO. 507 ILLUSTRATION INDEX

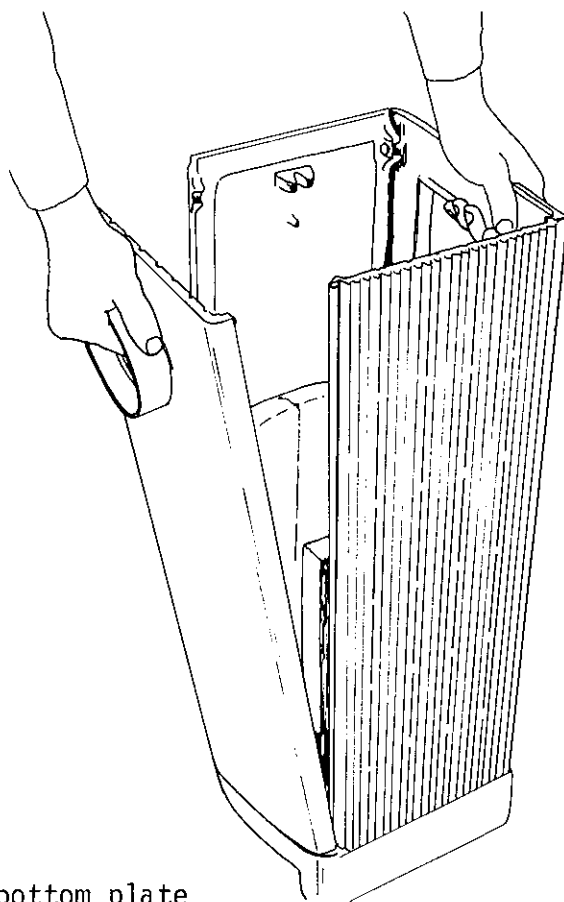

Cement applied to bottom plate	507A
Back plate	507B
Front plate	507C
Removing back plate	507D
Removing furnace cement	507E
Cement applied to back edge of bottom plate	507F
Cement applied to back plate	507G
Cement applied to shaker grate hole in front plate	507H
Refractory cement applied to front plate firebrick	507I
Pressing the front plate firebrick into place	507J
Excess furnace cement	507K
Applying refractory cement to firebrick	507L
Cementing firebrick	507M, 507N
Bracing the side plates	507O

JOTUL NO. 507 REPAIR TIMES

<u>Part</u>	<u>Times</u>
Top Plate, Top Plate Gasket	10 minutes
Back Plate	1 hour, 15 minutes
Front Plate	1 hour
Side Plate	2½ hours
Removing loose firebrick (7 bricks) and recementing firebricks	½ hour <u>3/2 hr</u>
Door, Door Gasket	15 minutes
Bottom Plate	20 minutes

Repairs not specifically listed will be reimbursed on an individual basis.

Repair times will be periodically reviewed by Kristia Associates. Any changes will become effective 15 days following notification.

JOTUL NO. 507 STOVE DESCRIPTION

The Jøtul No. 507 consists of six interlocking plates. The front and back plates lock the side plates into position. All of these plates are locked at the lower edge by the bottom plate. A shaker grate housing rests on stops located on the front, back, and side plates. It supports the shaker grate, the firebrick, and the iron liners for the firebox. Vents in the three doors regulate air flow into the firebox and can be adjusted differently for various types and sizes of fuel. A baffle located over the firebox channels flue gases back over the fire before being expelled out the rear outlet. A top plate heat shield protects the top plate from the intense heat of the fire.

Stove repair for the Jøtul No. 507 can be divided into the following five categories:

1. Air leaks where furnace cement has been improperly applied
2. Broken machine screws or stripped threads in casting or machine screws
3. Casting defects
4. Machining defects, i.e. misaligned door pin holes
5. Damaged stove parts from shipping or overfiring

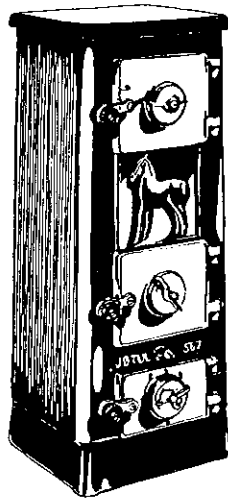

JOTUL NO. 507 DESIGN CHANGES

MACHINE SCREWS

English machine screws were used on stoves prior to April 1975. 6mm machine screws are now used instead of 1/4" screws. A 7/16" or an 11mm socket fits these English machine screws.

IT IS IMPORTANT TO HAND TIGHTEN THE MACHINE SCREWS AT FIRST TO BE SURE THAT THE PROPER SIZED SCREW IS BEING USED.

JOTUL NO. 507 TROUBLE SHOOTERS GUIDE

The Trouble Shooters Guide has been designed to help you solve special problems that haven't been included in the Part Replacement section. Keep in mind that some of the stoves will have problems that are difficult to identify at first. Others will require a combination of repairs listed in the guide. All of the stoves can be repaired.

There is nothing that can inoculate you with experience, but there are some things to remember that can save you headaches.

1. Unless you have done the repair before and know what is involved, do it in your workshop and not in the client's home.
2. If one repair doesn't work, try another.
3. Take the easiest and quickest solution to each problem. If, for instance, there is an air leak in one area of a door that is slightly warped, build out the door gasket at that point rather than replacing the door. Only in extreme cases, when all else fails, replace the door.

Or, if, for instance, there is an air leak between stove plates at one corner, apply cement to the inner seam first. If the problem is more severe, as a last resort, you will have to disassemble and recement the plates.

AIR LEAK IN DOOR SEAL

CAUSES:

Bent hinge pins
 or
 Door or front plate warped
 or
 Door gasket damaged or worn
 or
 Hinge pin or pin hole in door is offset in casting

SOLUTIONS:

Replace or straighten hinge pins (See Appendix)
 or
 Build out door gasket (See Appendix)
 or
 Replace asbestos gasket with smaller gasket where it binds with the front plate (See Appendix)
 or
 In extreme cases, replace door or front plate

DOOR SCRAPES FRONT PLATE WHEN CLOSING

CAUSES:

Bent hinge pins

or

Imperfect casting or machining of hinge arms on door

or

Hinge pin hole offset in door or front plate

SOLUTIONS:

Replace or straighten hinge pins (See Appendix)

or

In extreme cases, replace door or front plate

DOOR SITS CROOKED ON FRONT PLATE

CAUSES:

Bent hinge pins

or

Hinge pin hole offset in door or front plate

SOLUTIONS:

Replace or straighten hinge pins

or

In extreme cases, replace door or front plate

STRIPPED MACHINE SCREW THREADS IN CASTING

CAUSES:

Overtightening of machine screws

SOLUTIONS:

Tap out hole and replace screw with larger machine screws (See Appendix)

MACHINE SCREW SNAPS OFF IN CASTING

CAUSES:

Overtightening of machine screws

SOLUTIONS:

Use an easy-out or screw extractor to remove machine screw from casting (See Appendix)

MACHINE SCREW WON'T THREAD INTO HOLE

CAUSES:

Wrong sized machine screw
or
Furnace cement has hardened on casting threads

SOLUTIONS:

Check to see if stove uses English sized machine screws
or
Use tap to clean threads

CRACKED PLATE

CAUSES:

Overfiring
or
Shipping damage

SOLUTIONS:

Weld crack as a temporary measure (See Appendix)
or
Replace plate

NOTE: Do not use stove with cracked plate, since damage to other plates may result.

BLISTERED ENAMEL

CAUSES:

Overfiring

SOLUTIONS:

Learn to live with it
or
Replace plate

BLISTERED ENAMEL ON UPPER REGION OF BACK PLATE

CAUSES:

Overfiring caused by operating stove with top door open
or air vent open all the way

SOLUTIONS:

Replace back plate

WARPED PLATE

CAUSES:

Overfiring
or
Warped casting

SOLUTIONS:

Replace plate

DISCOLORED ENAMEL

CAUSES:

Condensate in new enamel was not cleaned from
stove in first firing

SOLUTIONS:

Clean area with hot soapy water. A scouring agent
will dull enamel.
or
Learn to live with it

STOVE WON'T HOLD A FIRE FOR PROPER LENGTH OF TIME

CAUSES:

Air leaks in door seal or in furnace cement

SOLUTIONS:

Replace or repair door gasket (See Appendix)
or
Apply furnace cement to seams on inside of firebox
at leaky joints
or
In extreme cases, disassemble plates and recement seams

AIR OR SMOKE LEAKS BETWEEN STOVE PLATES

CAUSES:

Improper application of cement in seams

SOLUTIONS:

Clean inside seam where it leaks with wire brush;
then apply furnace cement over seam

TOP PLATE ROCKS BACK AND FORTH

CAUSES:

Gasket not sitting flat in channel

SOLUTIONS:

Lift top plate off and re-position gasket

JOTUL NO. 507

DIRECTIONS FOR PART REPLACEMENT

PART: **JOTUL NO. 507 TOP PLATE** **TIME:** 10 minutes

TOOLS: Wire brush
 Scissors or razor knife
 Small paint brush
 Face mask
 Screw driver

PARTS & SIZES: Top Plate (Part #10), white water-based glue; a M6x12 machine screw attaches the top plate heat shield to the top plate

DIRECTIONS: Lift off the top plate and set it upside down on a workbench or on the floor.

 Do not put an enameled plate directly against concrete or steel, as this could scar its surface.

 Pull out the gasket (10mm x 1065mm) from the damaged plate and glue it into the new plate with a white water-based glue. (See Directions for Top Plate Asbestos Gasket Replacement)

 Unscrew the top plate heat shield and attach it to the new plate.

 Allow the white glue to dry for a few minutes before setting the top plate back into place.

 Press the palms of your hands against opposite sides of the top plate once it is in place. If there is a rocking motion from side to side, or from end to end, remove the plate and re-position the gasket so that it lies flat in the gasket channel.

PART: **JOTUL NO. 507**
 TOP PLATE ASBESTOS GASKET **TIME:** 15 minutes

TOOLS: Wire brush
 Scissors or razor knife
 Small paint brush
 Face mask

PARTS & SIZES: Asbestos gasket (10mm x 1065mm), white water-based glue

DIRECTIONS: **CAUTION: WEAR FACE MASK WHEN WORKING WITH ASBESTOS GASKET.**

 Lift off the top plate and set it upside down on a workbench or on the floor.

Do not put an enameled plate directly against concrete or steel, as this could scar its surface.

Pull out the old gasket and clean the gasket channel with a wire brush. BE ESPECIALLY CAREFUL NOT TO SCAR THE OUTSIDE EDGES OF THE ENAMELED TOP PLATE WITH THE BRUSH.

Measure and cut a 10mm gasket to the proper length. THE ENDS OF THE ROPE SHOULD BUTT TOGETHER BUT NOT OVERLAP.

Paint a liberal amount of a white water-based glue into the gasket channel.

Beginning at the midpoint of one edge, press the gasket into place.

Allow the white glue to dry for a few minutes before setting the top plate back into place.

Press the palms of your hands against opposite sides of the top plate once it is in place. If there is a rocking motion from side to side, or from end to end, remove the plate and re-position the gasket so that it lies flat in the channel.

PART: **JOTUL NO. 507 BACK PLATE** TIME: 1 hour, 15 minutes

TOOLS: 10mm or 11mm socket
 2" socket extension
 Socket wrench
 Screw driver
 Putty knife
 Tools for removing furnace cement (See Appendix)
 Brick hammer
 Rubber mallet
 Sponge
 Masonry trowel

PARTS & SIZES: Back Plate (Part #5), seven (M6x20) machine screws attach back plate to side and bottom plates; seven flat washers, 8 oz. furnace cement, 3½ lbs. refractory cement

DIRECTIONS: Lift off the top plate.
 Unbolt and remove the baffle plate.
 Tap the burn plates loose with a brick hammer, and remove them.
 Unscrew the seven machine screws (M6x20) which fasten the damaged back plate to the side and bottom plates. (See Illustration 507B)

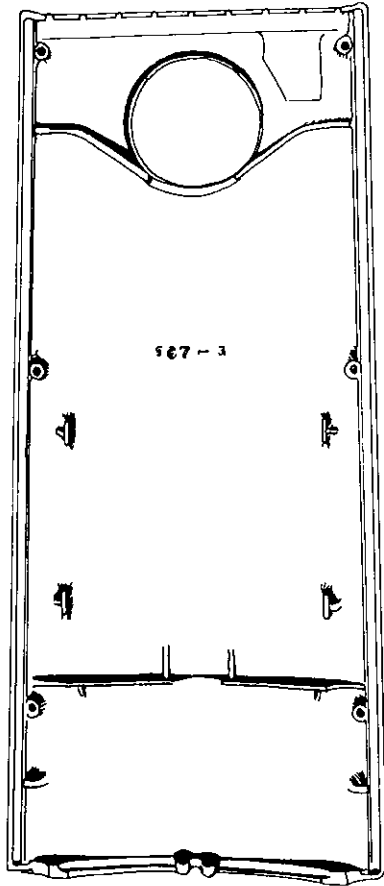

Illus. 507B

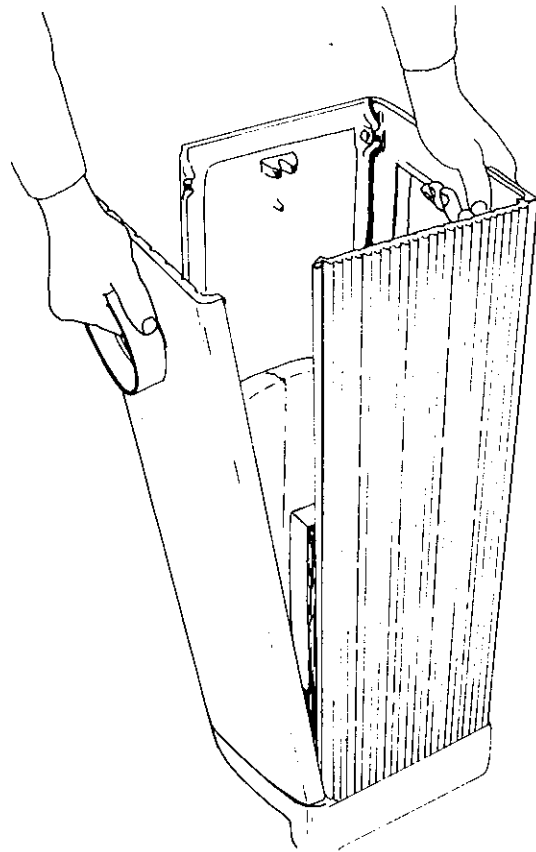

Illus. 507D

Pull the back plate off the stove (see Illustration 507D), and lift the two loosened rear firebricks (U.N.8) out of the firebox.

Clean the furnace cement from the exposed edges of the side and bottom plates. (See Appendix) A rotary rasp in an electric drill works well for this. (See Illustration 507E) Keep in mind that it is more important to provide a good surface for the cement to adhere to than to get all of the cement off. In some cases removing all the cement will be difficult and time consuming.

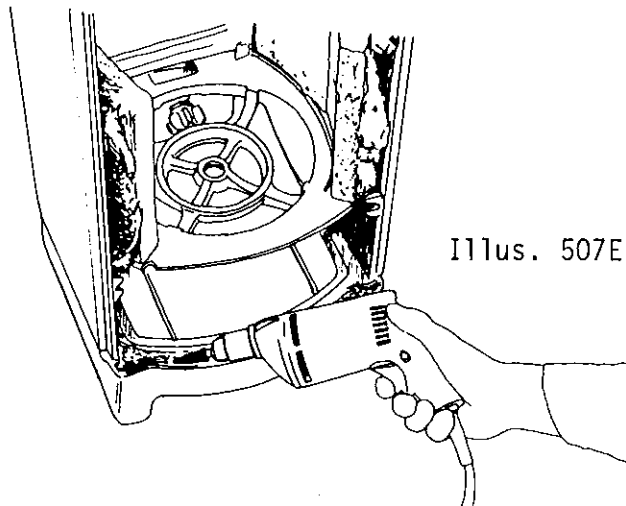

Illus. 507E

Chip refractory cement from the two loose firebrick. (See Appendix)

Apply furnace cement to the bottom plate. (See Illustration 507G)

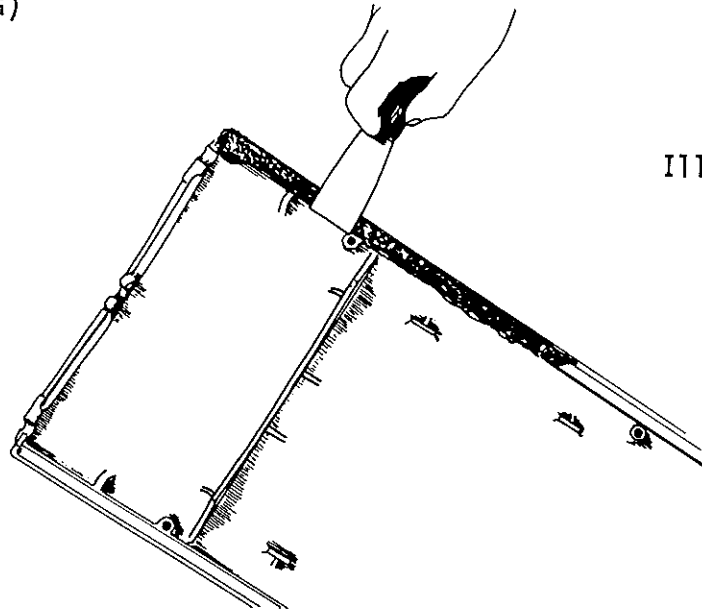

Illus. 507G

APPLY EXTRA CEMENT AT THE CORNERS WHERE AIR LEAKS ARE MOST LIKELY TO OCCUR. Be careful not to fill the machine screw holes in the back plate with cement.

Set the new back plate onto the bottom plate and press it into position.

If the furnace cement has been applied properly, excess cement will squeeze out into the firebox. In addition, some cement may squeeze to the outside at the corners. (See Illustration 507K)

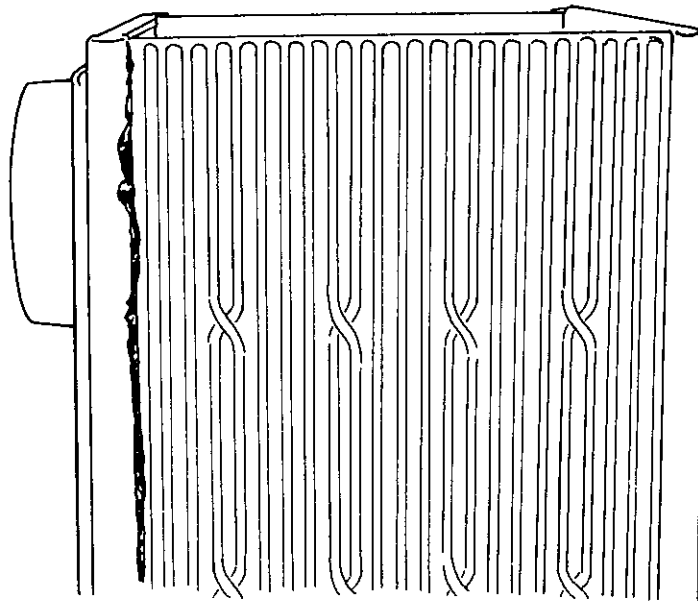

Illus. 507K

Hand tighten all of the back plate machine screws. Use washers on all of the machine screws.

If you are having trouble inserting a machine screw, use a wooden brace to help align the side plates. (See Illustration 5070)

Illus. 5070

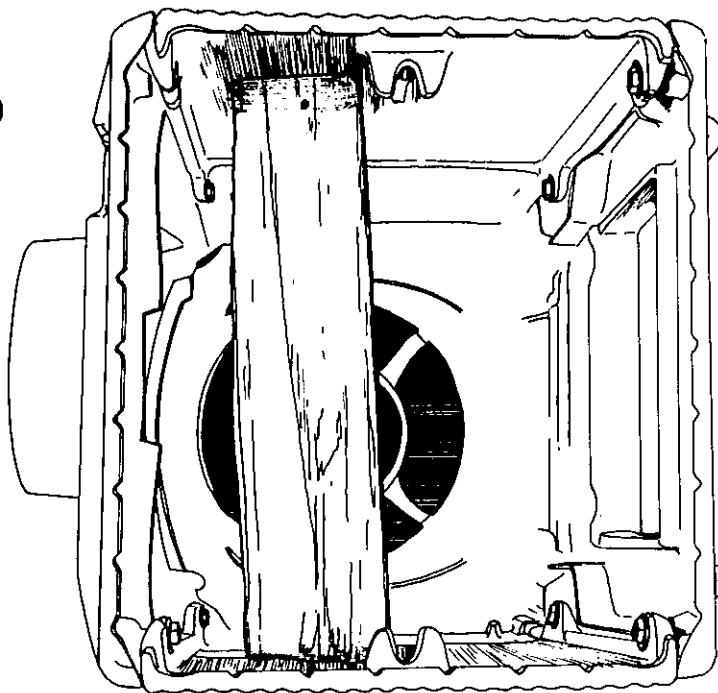

With a socket wrench tighten the machine screws until firm. DO NOT OVERTIGHTEN AS THIS WILL RESULT IN STRIPPED THREADS.

Remove the excess cement which has squeezed to the outside with a putty knife, and finish cleaning with a soapy sponge.

Set the two firebricks into place dry. You will notice that one edge of the brick is beveled while the other is straight. Place the beveled edge toward the front.

Remove the firebricks, and spread cement onto the outer surface and the front edge of one firebrick. (See Illustration 507L)

Illus. 507L

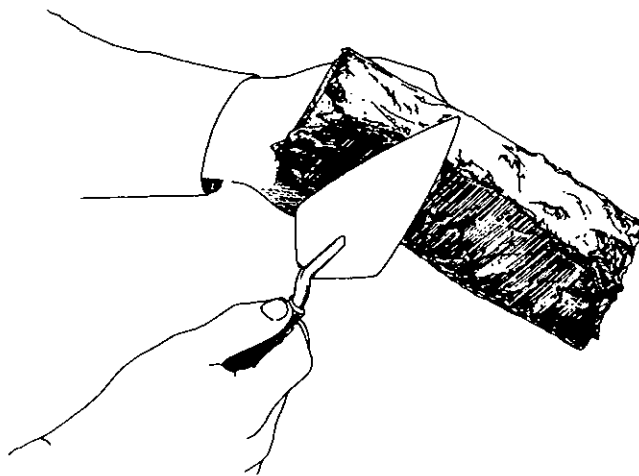

Press the brick into place. (See Illustration 507M) Cement will squeeze out around the firebrick.

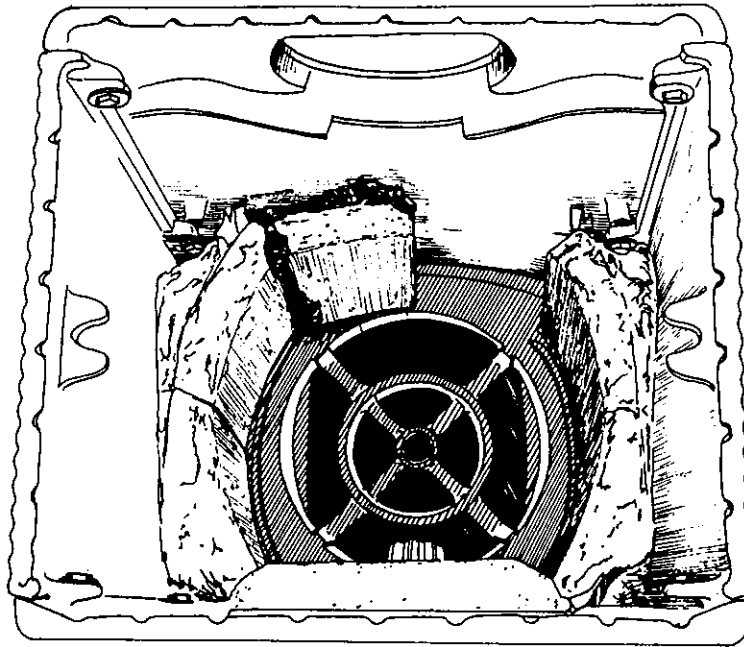

Illus. 507M

Spread cement onto the outer surface and the edges of the second brick.

Slide this brick into position from above.

It is not important to fill all the space behind the bricks at the corners with refractory cement. Air spaces will not affect the durability of the repair job. It is more important to make sure that there is some refractory cement between each firebrick.

Spread cement over the upper edge of the bricks. (See Illustration 507N)

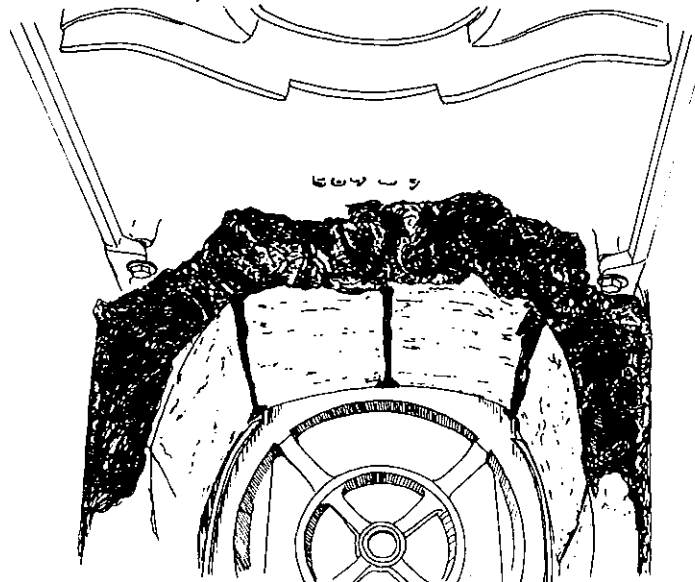

Illus. 507N

Press the side and back burn plates into place.

Scrape off any excess cement with the trowel.

Reattach the baffle and the top plate.

Allow the refractory cement to cure 3-5 days before firing.
Then keep the first few fires small.

PART: **JOTUL NO. 507 FRONT PLATE** **TIME: 1 hour**

TOOLS: 10mm or 11mm socket
 2" socket extension
 Socket wrench
 Screw driver
 Putty knife
 Tools for removing furnace cement (See Appendix)
 Rubber mallet
 Brick hammer
 Sponge
 Masonry trowel

PARTS & SIZES: Front Plate (Part #7), six (M6x20) machine screws attach back plate to side and bottom plates; six flat washers, 8 oz. furnace cement, refractory cement

DIRECTIONS: Lift off the top plate and all of the doors.

Unbolt and remove the baffle plate.

Tap the burn plates loose with a brick hammer, and remove them.

Unscrew the six machine screws (M6x20) that fasten the damaged front plate to the side plates. (See Illustration 507C)

Illus. 507C

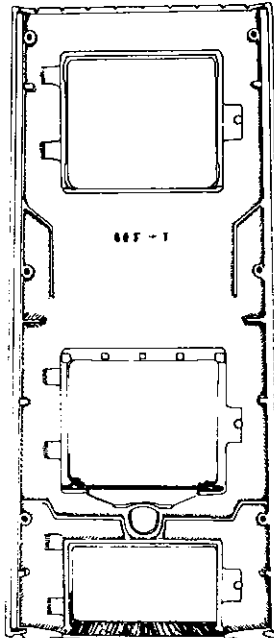

Pull the front plate off the stove. Remove the loosened front firebricks (U.N.F 19) and the front grate housing from the front plate.

Clean the furnace cement from the exposed edges of the side and bottom plates. (See Appendix) A rotary rasp in an electric drill works well for this. Keep in mind that it is more important to provide a good surface for the cement to adhere to than to get all the cement off. In some cases removing all the cement will be difficult and time consuming.

Apply furnace cement to the bottom plate.

Apply furnace cement to the edges of the new front plate.

APPLY EXTRA CEMENT AT THE CORNERS WHERE AIR LEAKS ARE MOST LIKELY TO OCCUR. Be careful not to fill the machine screw holes in the front plate with cement.

Apply furnace cement to the shaker grate hole in the front plate. (See Illustration 507H)

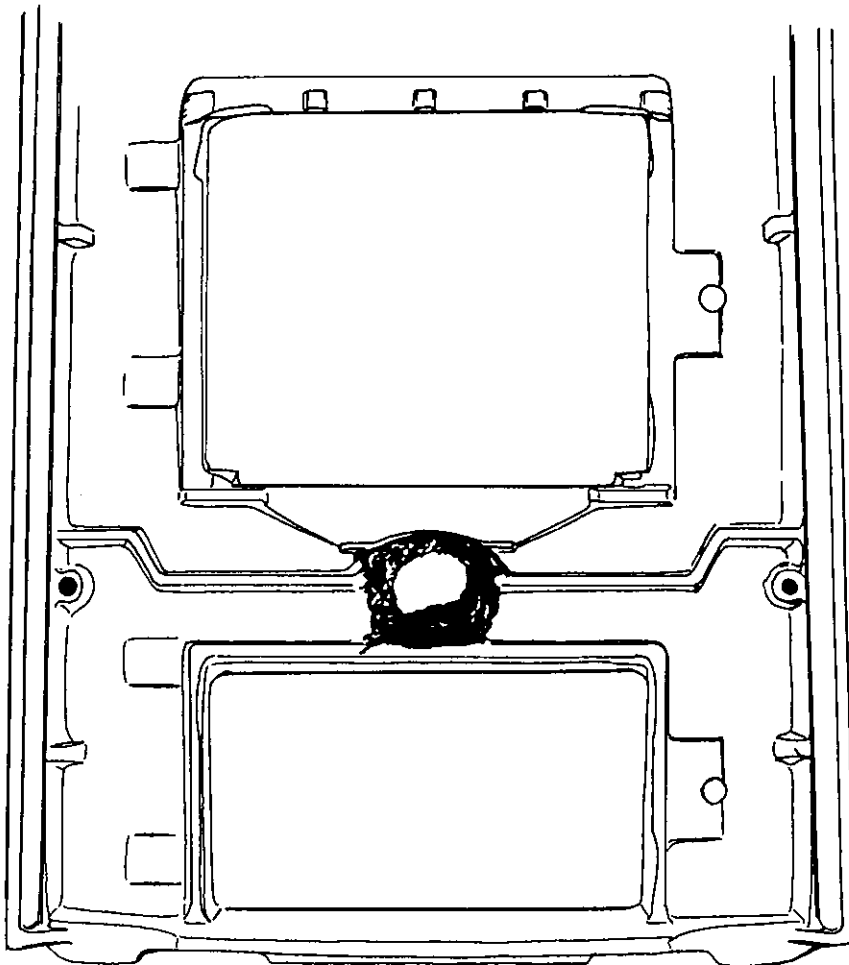

Illus. 507H

Spread refractory cement on the front firebrick (U.N.F 19).
(See Illustration 507I)

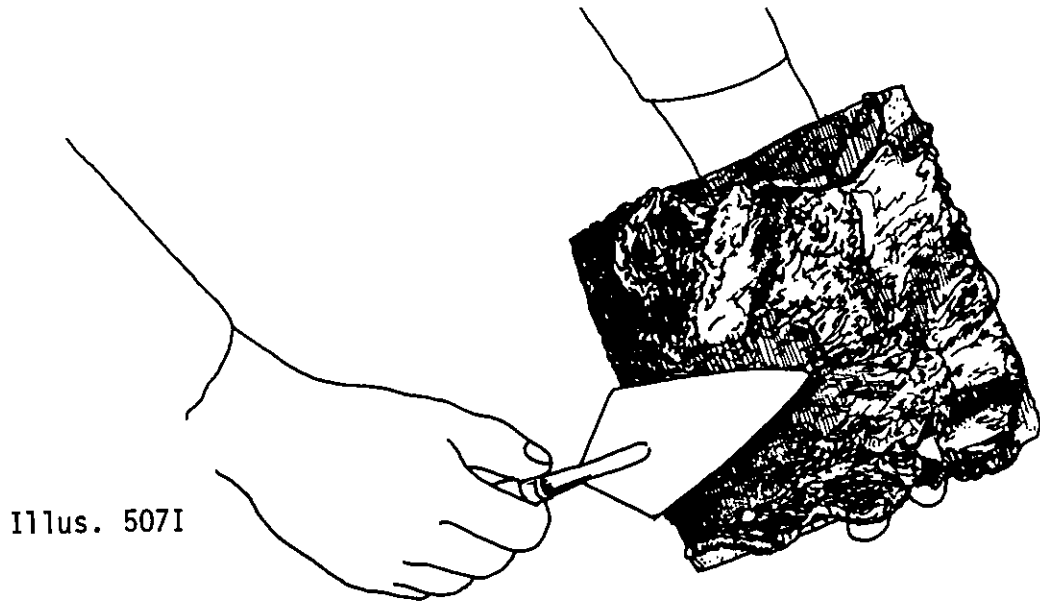

Illus. 507I

Set the front grate housing against the front plate, and
press the brick into place. (See Illustration 507J)

Illus. 507J



Set the lower edge of the new front plate onto the bottom plate and press it into position.

Hand tighten all the front plate machine screws. Use washers on all machine screws.

If you are having trouble inserting a machine screw, use a wooden brace to help align the side plates. (See Illustration 5070)

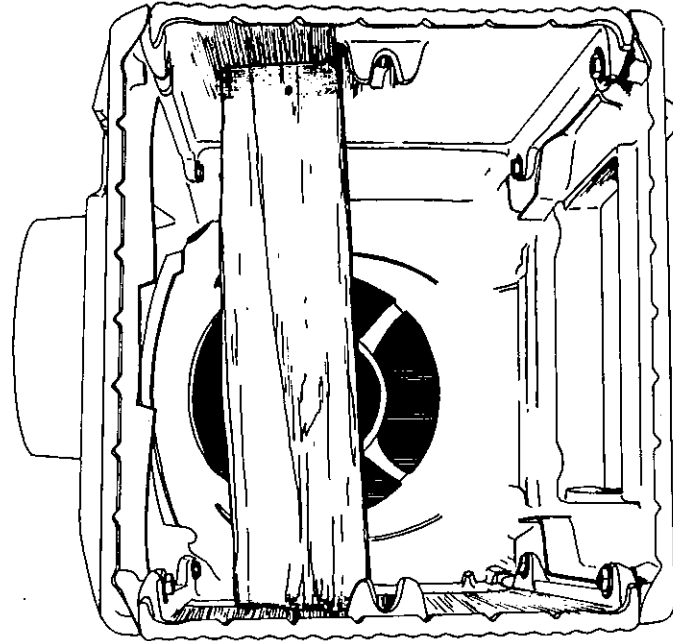

Illus. 5070

With a socket wrench tighten the machine screws until firm. DO NOT OVERTIGHTEN AS THIS WILL RESULT IN STRIPPED THREADS.

Remove the excess cement which has squeezed to the outside with a putty knife, and finish cleaning with a soapy sponge.

Spread refractory cement over the upper edge of the bricks. (See Illustration 507N)

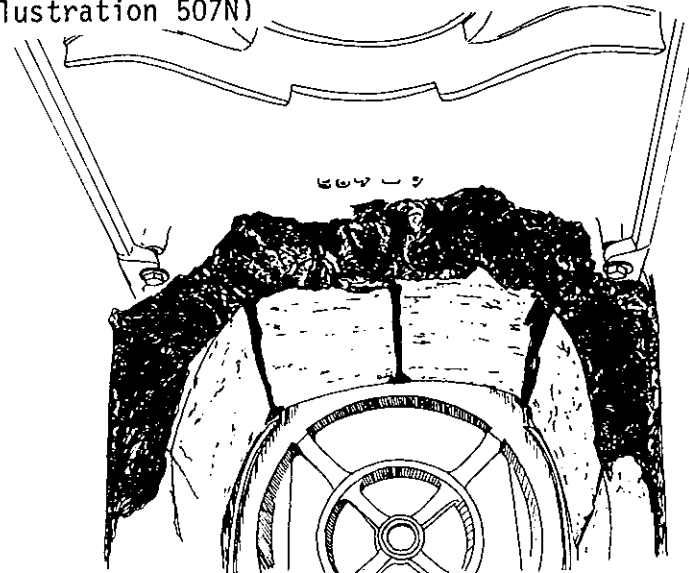

Illus. 507N

Press the side and back burn plates into place.

Reattach the baffle, top plate, and the doors.

Allow the refractory cement to cure 3-5 days before firing.
Then keep the first few fires small.

PART: JOTUL NO. 507 SIDE PLATE

TIME: 2½ hours

TOOLS: 10mm or 11mm socket
2" socket extension
Socket wrench
Putty knife
Screw driver
Tools for removing furnace cement (See Appendix)
Rubber mallet
Brick hammer
Masonry trowel
Sponge

PARTS & SIZES: Side Plate (Part #6), seven (M6x20) machine screws attach each side plate to the front, back, and bottom plates; seven flat washers, 1¼ lbs. furnace cement, 9½ lbs. refractory cement

DIRECTIONS: The stove must be disassembled in order to replace a side plate.

Lift off the top plate and all of the doors.

Unbolt and remove the baffle plate.

Tap the burn plates loose with a brick hammer, and remove them.

Unscrew the seven machine screws (M6x20) that fasten the back plate to the side and bottom plates. (See Illustration 507B)

Illus. 507B

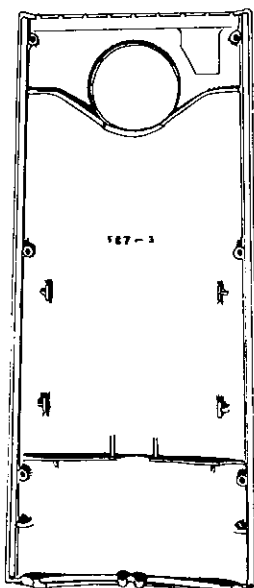

Pull the back plate off the stove (see Illustration 507D), and lift the two loosened rear firebricks (U.N. 8) out of the firebox.

Unscrew the six machine screws that fasten the front plate to the side plates. (See Illustration 507C) Unscrew the machine screw that fastens each side plate to the bottom plate.

Illus. 507D

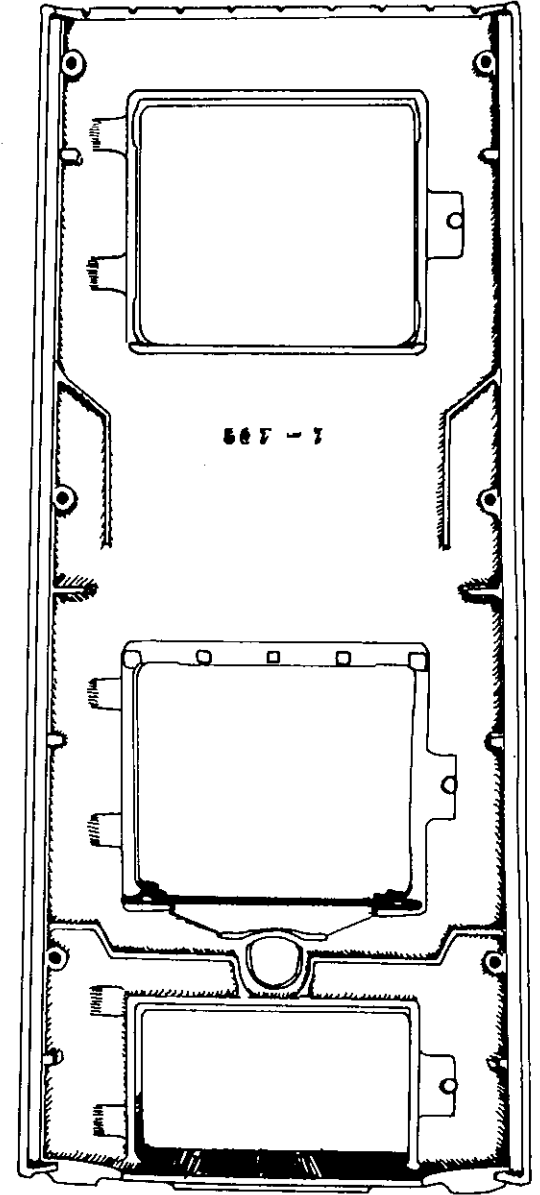
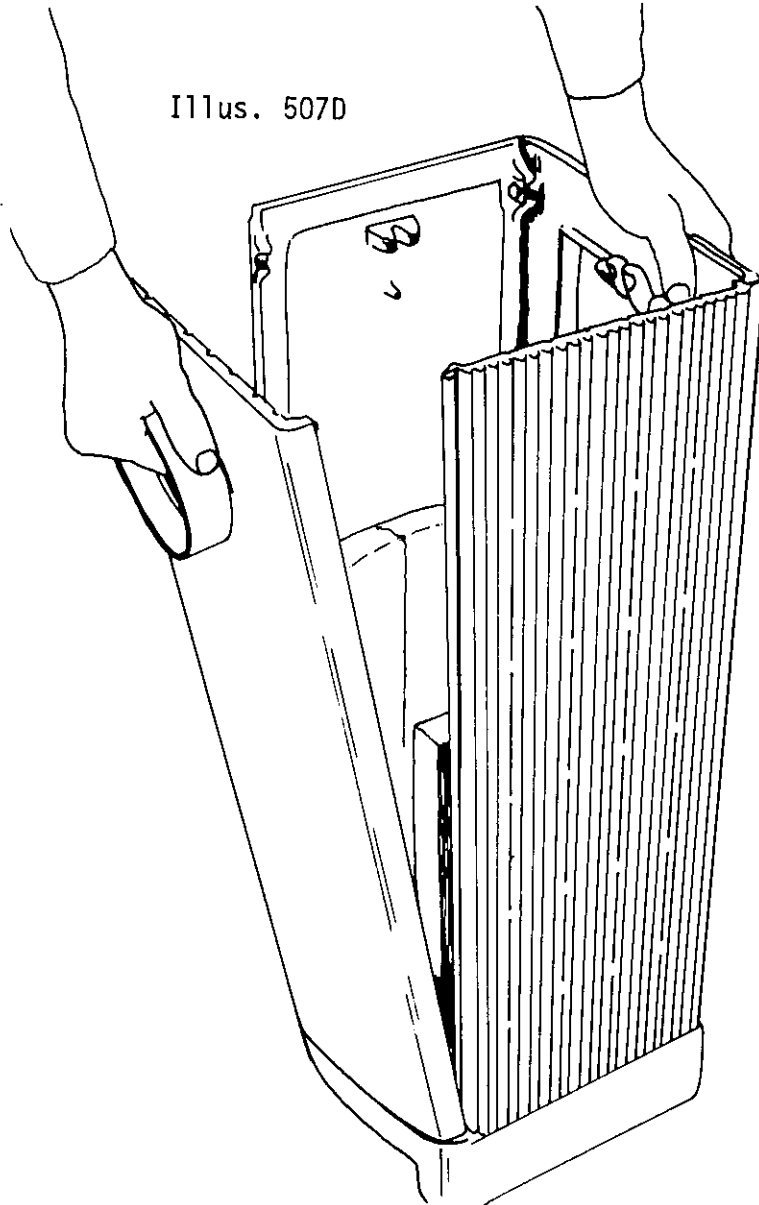

Illus. 507C

Pull the front and side plates loose.

Chip the furnace cement from all the stove plates. (See Appendix) Keep in mind that it is more important to provide a good surface for the cement to adhere to than to get all the cement off. In some cases removing all the cement will be difficult and time consuming.

Chip the refractory cement from the loose firebricks. (See Appendix)

Apply furnace cement to the bottom plate. (See Illustration 507F)

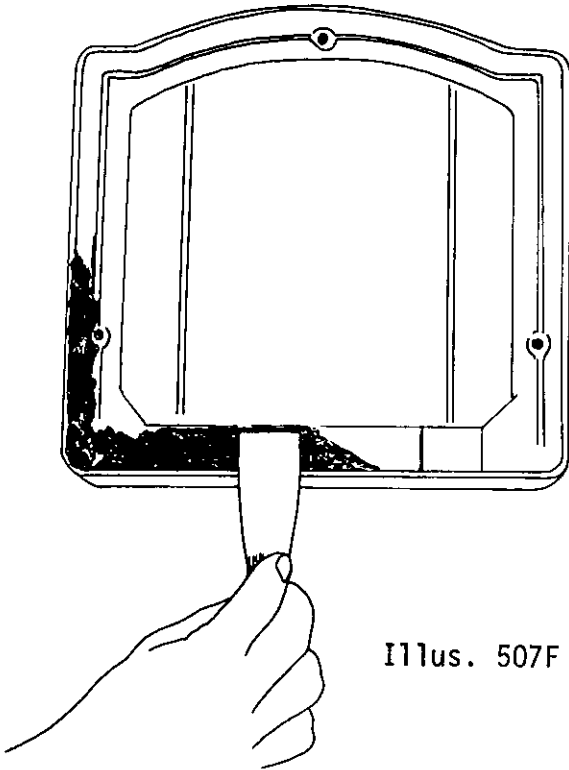

Illus. 507F

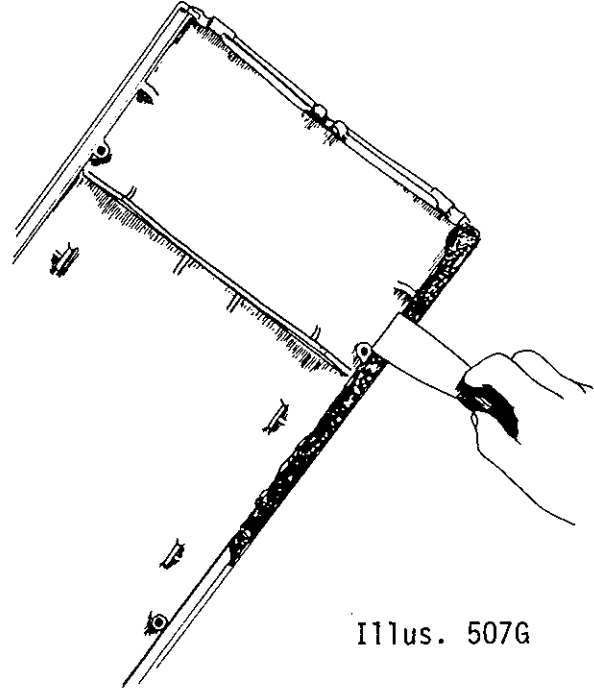

Illus. 507G

Apply furnace cement to the edges of the back plate (see Illustration 507G), and to the front plate (see Illustrations 507H and 507J).

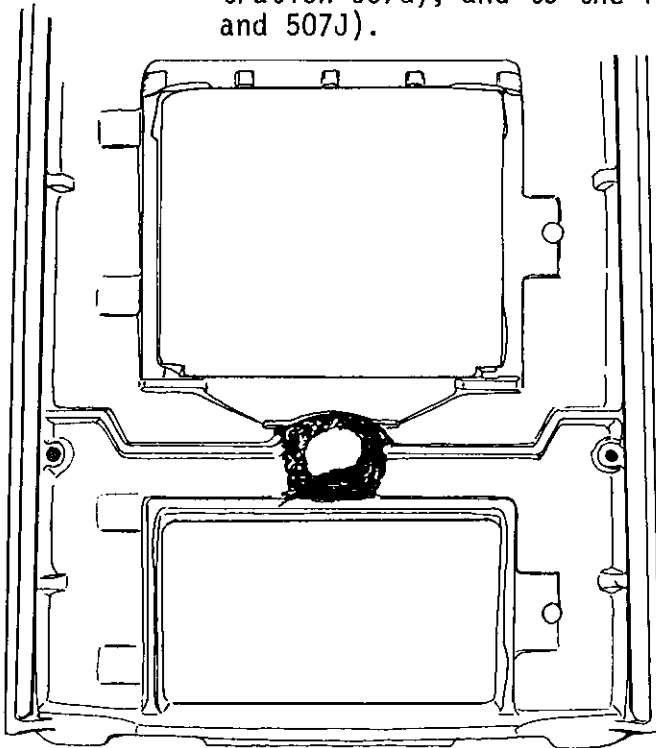

Illus. 507H

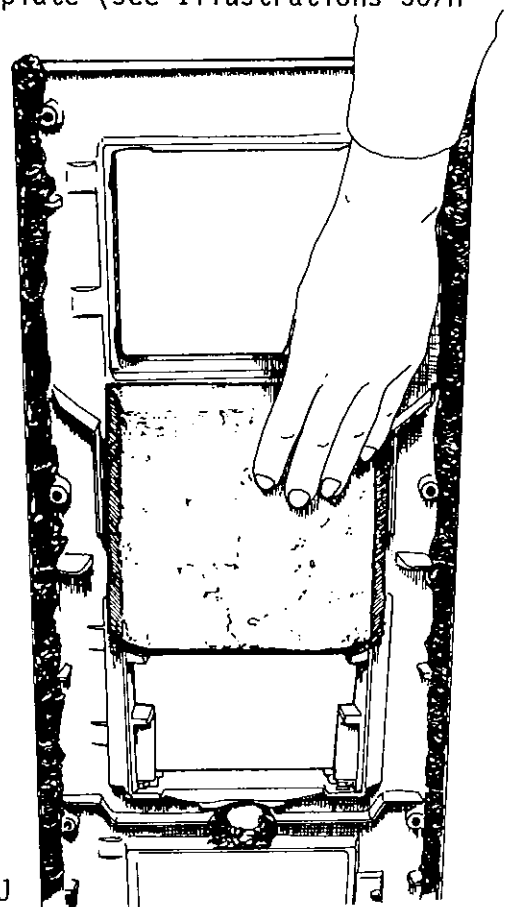

Illus. 507J

APPLY EXTRA CEMENT AT THE CORNERS WHERE AIR LEAKS ARE MOST LIKELY TO OCCUR. Be careful not to fill the machine screw holes in the back or front plates with cement.

Begin assembling the plates by pressing the back plate and one side plate into position on the bottom plate. Hand tighten the machine screws which fasten these plates together.

Hold the shaker grate housing in position while pressing the second side plate into place.

Hand tighten the machine screws.

If the furnace cement has been applied properly, excess cement will squeeze out into the firebox. In addition, some cement may squeeze to the outside at the corners. (See Illustration 507K)

Illus. 507K

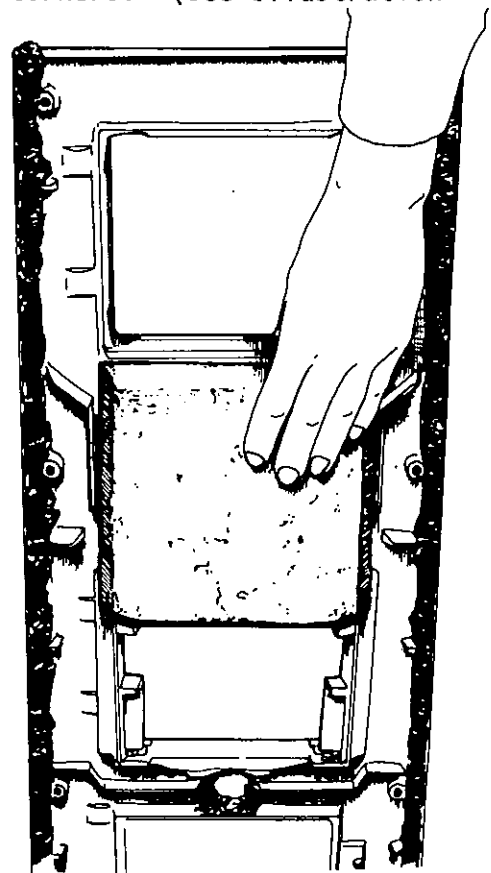
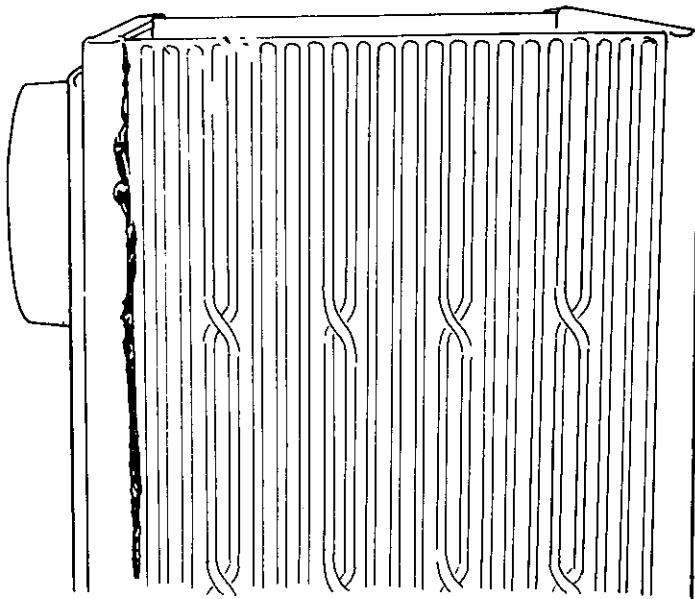

Illus. 507J

Spread refractory cement onto the front firebrick (U.N.F 19).

Set the front grate housing against the front plate, and press the brick into place. (See Illustration 507J)

Set the lower edge of the front plate onto the bottom plate, and press it into position.

Hand tighten the front plate machine screws. Use flat washers on all machine screws.

If you are having trouble inserting a machine screw, use a wooden brace to help align the side plates. (See Illustration 5070).

Illus. 5070

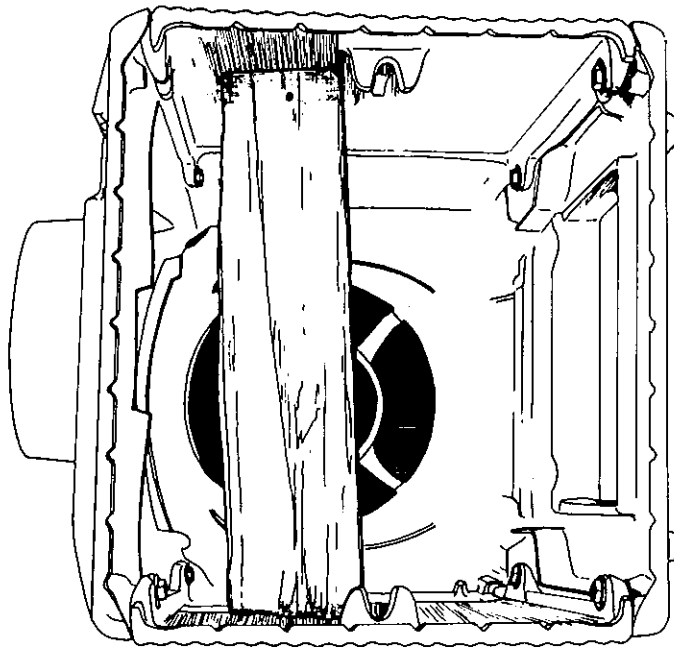

With a socket wrench, tighten the machine screws until firm. DO NOT OVERTIGHTEN AS THIS WILL RESULT IN STRIPPED THREADS.

Remove the excess cement which has squeezed to the outside with a putty knife, and finish cleaning with a soapy sponge.

Set the firebrick into place dry. You will notice that one edge of the brick is beveled while the other is straight. Line them up, alternating the beveled edges according to the schematic.

Remove the firebrick.

Spread refractory cement onto the outer surface and rear edge of the first firebrick on the right or left. (See Illustration 507L)

Press the brick into place.

Illus. 507L

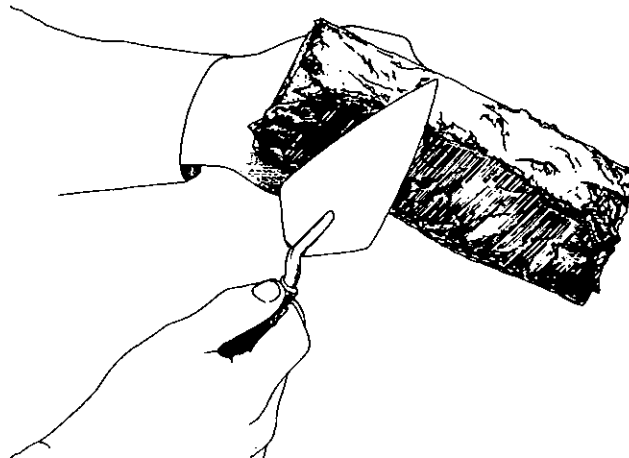

Repeat this procedure for the remaining brick. You will have to slide the last brick into position from above.

It is not important to fill all the space behind the corner bricks with refractory cement. Air spaces will not affect the durability of the repair job. It is more important to make sure that there is some refractory cement between each firebrick.

Spread cement over the upper edge of the bricks. (See Illustration 507N)

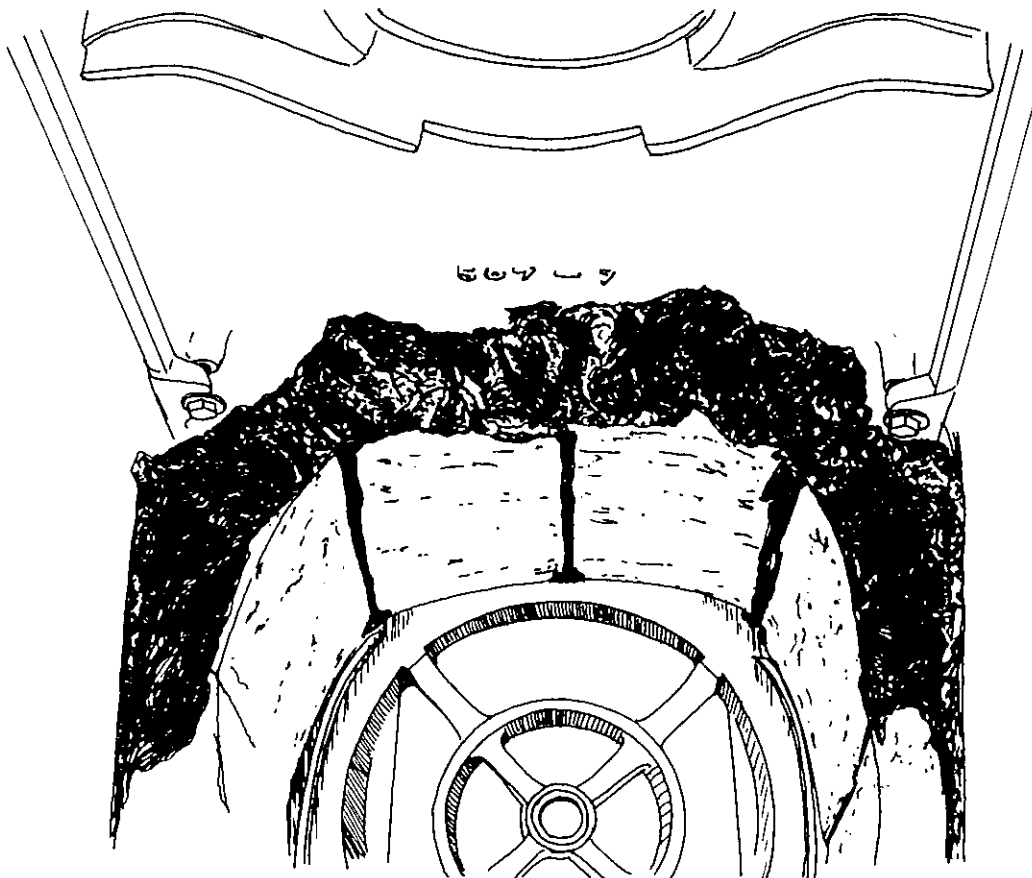

Illus. 507N

Press the side and back burn plates into place.

Scrape off any excess cement with a trowel.

Reattach the baffle and the top plate.

Allow the refractory cement to cure 3-5 days before firing. Then keep the first few fires small.

TOOLS: 10mm or 11mm socket
 2" socket extension
 Socket wrench
 Putty knife
 Tools for removing furnace cement (See Appendix)
 Sponge

PARTS & SIZES: Bottom Plate (Part #36), three (M6x20) machine screws attach bottom plate to side and back plate; three flat washers, furnace cement

DIRECTIONS: Lift off the top plate and all of the doors.

Unscrew the three machine screws which fasten the bottom plate to the side and back plates.

Lift the assembled upper portion of the stove off the bottom plate and set it on its side on a workbench or the floor.

Chip the furnace cement from the exposed edges of the assembled plates. (See Appendix)

Apply furnace cement to the new bottom plate. (See Illustration 507F)

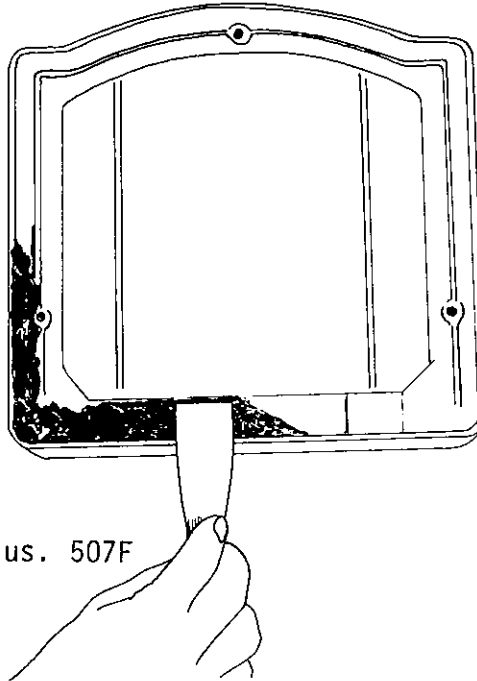

Illus. 507F

APPLY EXTRA CEMENT AT THE CORNERS WHERE AIR LEAKS ARE MOST LIKELY TO OCCUR.

Set the assembled upper portion back onto the bottom plate and hand tighten the machine screws.

If the cement has been applied properly, excess cement will squeeze out into the firebox. In addition, some cement may squeeze to the outside at the corners.

With a socket wrench tighten the machine screws until firm.
 DO NOT OVERTIGHTEN AS THIS WILL RESULT IN STRIPPED THREADS.

Remove any excess cement which has squeezed to the outside
 with a putty knife, and finish cleaning with a soapy sponge.

Replace the top plate and the doors.

PART: **JOTUL NO. 507 DOOR GASKETS** TIME: 10 minutes per door

TOOLS: Scissors or razor knife
 Small paint brush
 Wire brush
 Face mask

PARTS & SIZES: Two asbestos rope gaskets ($\frac{1}{4}$ " x 633mm), ash door gasket
 ($\frac{1}{4}$ " x 540mm), waterglass

DIRECTIONS: CAUTION: WEAR A FACE MASK WHEN WORKING WITH ASBESTOS ROPE.

Remove the door and set it on a workbench or on the floor.

Pull out the old gasket.

Thoroughly clean the door gasket channel with a wire brush.

Carefully paint waterglass into the channel. (Waterglass
 turns white when it dries. It will also permanently stain
 green enamel.)

Cut a piece of $\frac{1}{4}$ " asbestos rope to the proper length. To
 prevent the rope from unraveling, wet both ends with water-
 glass.

Starting from the midpoint of the upper or lower edge, press
 the gasket into place. THE ENDS SHOULD BUTT TOGETHER BUT
 NOT OVERLAP.

Open and close the door a few times to be sure the gasket is
 seated properly and is airtight.

After you have checked for air leaks, leave the door open for
 a few hours while the waterglass dries. (This will prevent
 any waterglass which has squeezed out from behind the gasket
 from sticking to the front plate.)

JOTUL NO. 507 DOOR HANDLE CATCH

TIME: 30 minutes

TOOLS: $\frac{1}{4}$ " electric drill
 $\frac{1}{2}$ " metal drill bit
Center punch
Adjustable wrench
Screw driver
Pliers
Hack saw

PARTS & SIZES: Door Handle Catch (Part #25), bolt (M8x20) with nut and lock washer

DIRECTIONS: Saw off the end of the handle catch.

With a center punch and hammer, mark the center of the latch rivet.

Drill away the head of the rivet with a $\frac{1}{2}$ " drill bit.

Tap the rivet loose with the center punch and hammer, and pull the rivet out from the inside.

Insert a fillister head bolt (M8x20) through the new handle catch and the front plate, and fasten it with a lock washer and nut.

In order to replace the middle catch, one of the firebricks will have to be removed.

PART: **JOTUL NO. 507 DOOR PINS**

TIME: 5 minutes

TOOLS: Nail punch
Hammer
Pliers

PARTS & SIZES: Door Pins

DIRECTIONS: A sharp tap from above will loosen straight pins enough so that they can be pulled out from below with pliers. Be careful not to peen over the top of these pins as this will make them more difficult to remove.

PART: **JOTUL NO. 507 FIREBRICKS** TIME: 30 minutes,
removing loose
firebrick and
recentering
firebrick

TOOLS: 10mm or 11mm socket
Socket wrench
Screw driver
Brick hammer
Masonry trowel

PARTS & SIZES: Firebrick: four (U.N. 11), two (U.N. 8), one (U.N.F 19);
9½ lbs. refractory cement

DIRECTIONS: If the firebricks are loose, pull them free and clean the
loose debris from the firebox.

If the firebricks are firmly cemented in place, it will be
easier to remove them if the front plate is first removed.
(See Front Plate Replacement Directions)

Spread refractory cement onto the front firebrick (U.N.F 19).
(See Illustration 507I)

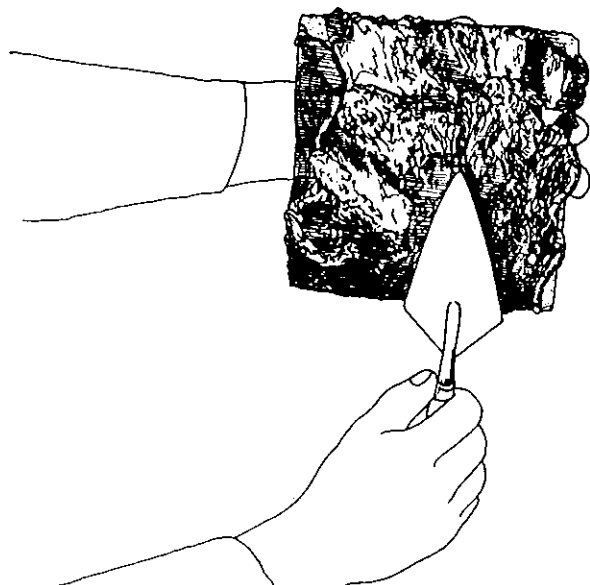

Illus. 507I

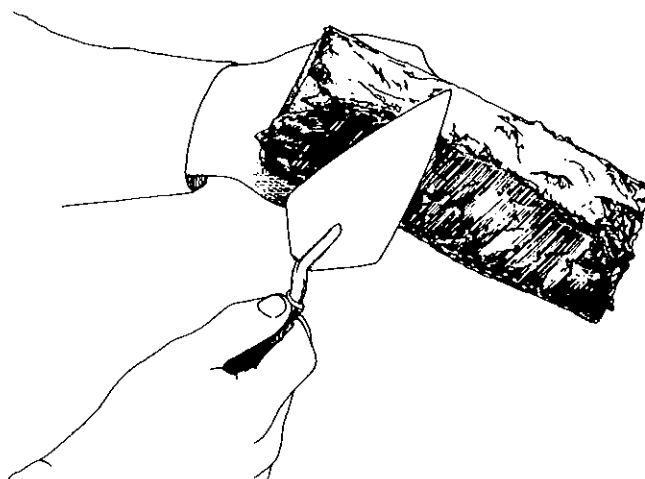

Illus. 507L

Set the front grate housing against the front plate, and
press the brick into place.

Set the remaining firebricks into place dry. You will notice
that one edge of each brick is beveled while the other is
straight. Line them up, alternating the beveled edges
according to the schematic.

Remove the loose firebricks.

Spread refractory cement onto the outer surface and rear
edge of the first firebrick on the right or left. (See
Illustration 507L)

Press the brick into place.

Repeat this procedure for the remaining bricks. You will have to slide the last brick into position from above.

It is not important to fill all the space behind the bricks at the corners with refractory cement. Air spaces will not affect the durability of the repair job. It is more important to make sure that there is some refractory cement between each firebrick.

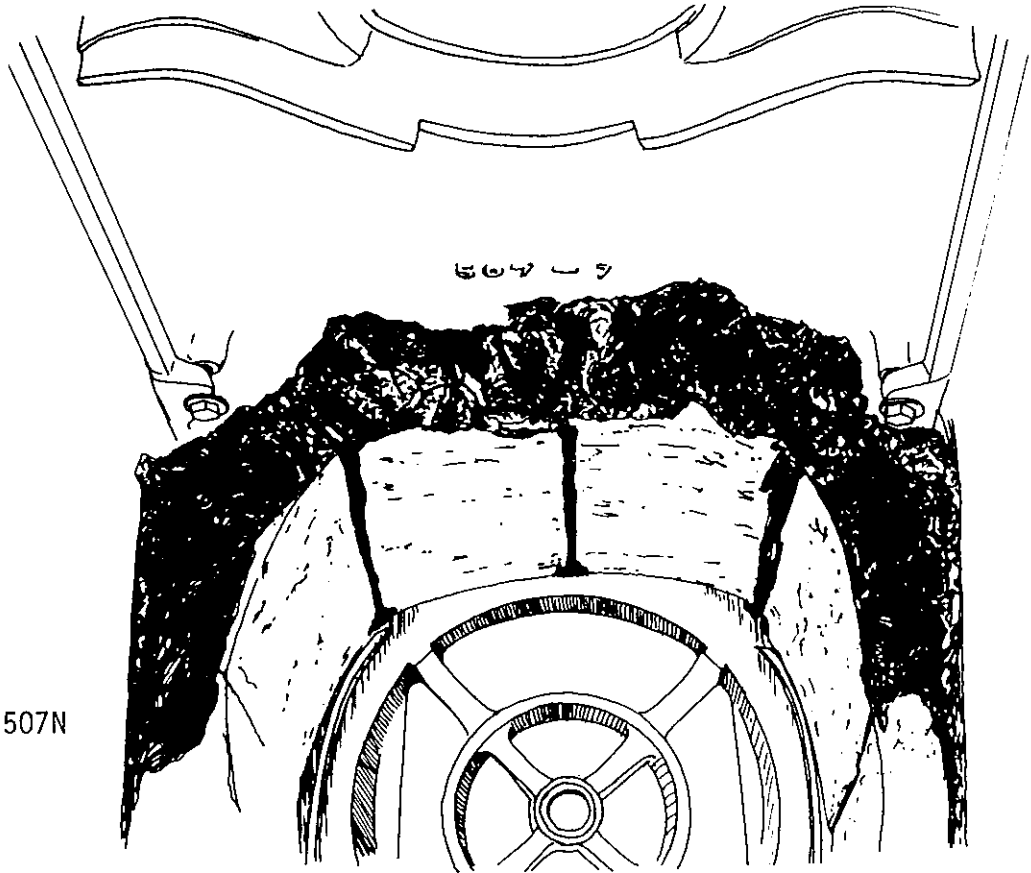

Illus. 507N

Spread refractory cement over the upper edge of the bricks.
(See Illustration 507N)

Press the side and back burn plates into place.

Scrape off any excess cement with the trowel.

Reattach the baffle.

Allow the refractory cement to cure 3-5 days before firing.
Then keep the first few fires small.

PART: **JOTUL NO. 507 SHAKER GRATE** TIME: 2½ hours

TOOLS: 10mm or 11mm socket
2" socket extension
Socket wrench
Putty knife
Screw driver
Tools for removing furnace cement (See Appendix)
Rubber mallet
Brick hammer
Masonry trowel
Sponge

PARTS & SIZES: Shaker Grate Housing (Part #9), 1¼ lbs. furnace cement,
9½ lbs. refractory cement.

DIRECTIONS: The stove must be disassembled in order to replace the
shaker grate housing. (See Directions for Side Plate
Replacement)

The shaker grate fits into the shaker grate housing and
can be lifted free when the stove is assembled.